

Release 1, 06/30/08 Preliminary

## **Operation & Service information for Jaguar E-type Ser 1 6-wire wiper motor system.**

**By  
Dick Vandermeiden**

This document explains the workings of the Jaguar p/n 8594 (Lucas DL-3, 75404) wiper motor system. Note that this covers the verified LH drive version only. While most of this information generally covers the RH drive version as well (Lucas DL-3, 75403), the exact differences between Lucas 75404 and 75403 have not been determined. Also note that some motors have a thermal overload switch build in while others don't have one. It appears that the Lucas 75404D/E models had a thermal overload switch which was subsequently deleted beginning with Lucas 75404F. I have samples of a Lucas 75404E (date code 1/66) with a thermal switch and also a Lucas 75404F (date code 12/66) without a thermal switch. The 3.8 Operating Manual refers to such a thermal switch and so it appears to have been an early feature only. Other than the thermal cutout switch there are no differences in the wiper systems in the Ser 1 cars and this document should apply to all cars from early 1961 to the end of 1967. You can check for the presence of a thermal cutout switch on the side of the motor housing near the end plate. If the motor is still mounted in the car, this is underneath the motor. If a thermal cutout switch is present, two bend-over tabs can be felt which protrude through two holes in the motor housing. If there are no tabs and no holes, then the motor has no thermal cutout switch.

When the system is in good shape, the SLOW position allows the wipers to operate 44 – 48 cycles/minute at 3 – 3.7 Amp. FAST is 58 – 68 cycles/minute at 2.2 – 2.9 Amp.

With the motor alone on the bench (no wipers/rack attached, but with gear box) SLOW motor current is 2.5 – 3.2 Amp and on FAST it is 1.7 – 2.4 Amp.

January 1968 (Ser 1-1/2) saw the introduction of another version of the wiper motor where the parking switch was relocated from the wiper rack to the gear box of the wiper motor. That system uses a 4-wire wiper motor, Lucas Model DL-3, 75658, which also does not have a thermal overload cutout switch. The dash board operating switch was changed from a 3-position toggle switch to a 3-position rocker switch.

## DASHBOARD CONTROL SWITCH, SER 1

The wiper system is operated by the driver using a 3-position toggle switch mounted in the central dash board. There are 3 positions, OFF, SLOW and HIGH. The part numbers for this switch are Jaguar C.15456, Lucas 31966.

The switch is a complicated design and it has 6 contact blades on the back numbered 1 - 6. Operational continuity of the contacts is as follows:

OFF POSITION	4 - 6 3 - 5
SLOW SPEED	4 - 5 2 - 3 - 6
HIGH SPEED	4 - 5 1 - 2 - 3

Frequently, the switch operates erratically due to the dielectric grease inside having dried up over the years. It is possible to open the switch by releasing the 5 retainer clips on the back very carefully. Allow the bakelite back section to come up slowly, so that no springs, balls or contact bars are propelled out. Make a note of what fits where, so that it can be reassembled exactly as before after cleaning. Use good quality silicone grease during reassembly that will last a lot longer than the traditional dielectric grease.

## PARKING SWITCH, SER 1

A very essential and often troublesome part of the wiper system is the parking switch. This is located on the wiper rack where the 3 wiper spindles are mounted. It consists of a copper segment that is attached to the center of the wiper rack and which is electrically floating, and with a wire attached (Red). The angular position of this segment is controlled by a flexible cable and a knob on the firewall inside the engine compartment. A copper contact finger is attached to the center wiper arm and this is permanently grounded. The copper contact finger is touching the copper segment while the wipers are operating at any speed and also while in the OFF position, prior to the wipers reaching the parking location at the lower edge of the windscreen.

The purpose of the parking switch is to provide a ground connection to the wiper motor while it is advancing the wipers to the parking position at the lower edge of the windscreen. As soon as the parking position is reached, the copper contact finger loses contact with the copper segment and the parking lead (Red) is no longer connected to ground. The exact position where this happens can be controlled with the flexible cable

and the control knob in the engine compartment. This allows for very fine adjustment of the wiper parking position.

### GENERAL OPERATING PRINCIPLE

When the control switch is moved from OFF to SLOW, contacts in the operating switch bypass the parking switch, and supply 12 V battery voltage to an armature and also to a field coil (8.5 - 9.5 Ohm). This causes the motor to start rotating CW at a low speed and the wipers leave the parking position to wipe an arc on the windscreen, that starts about 1" above the lower windscreen edge. Note that the wipers do not return all the way back to the parking location while operating on SLOW or FAST.

When the control switch is moved from SLOW to FAST, the field coil wiring is changed so that a fixed resistor (9.5 - 11 Ohms) is now in series with the field coil (8.5 - 9.5 Ohm). This causes the motor to rotate CW at a higher speed. The wipers still cover the same sweep arc as on low speed.

When the control switch is moved from SLOW to OFF, the field coil connections are reversed and the motor now turns CCW at a low speed. This causes a change in location of the pivot at the end of the motor crank where it meets the connecting rod. This in turn causes a change in the arc the wipers sweep over the windscreen. The offset allows the wipers to reach the parking position at the lower end of the windscreen whereas before they could only get as close as 1". While the wiper system is moving itself to the parking position, the motor is grounded only by the parking switch providing the ground path. Once the parking position is reached, the parking switch opens and the motor stops, leaving the wipers at the parking position.

The pivot rotates in an eccentric manner. When the motor reverses, the pivot rotates to its opposite extreme position, effectively increasing the length of the rod.

A common complaint is that the wipers work fine on SLOW and FAST, but do not return to the parking position when switched to OFF. They remain in a random position on the sweep arc as soon as the operating switch is in OFF. This is most commonly caused by the parking switch on the wiper rack having a problem. That can vary from a broken or bent copper grounding finger on the rack, which can be observed via the center opening behind the center dash board. It can also be caused by a missing wiring section (red) from the parking switch to contact #3 on the back of the operating switch. It can also be caused

by the finger or segment having worn out completely or by poor contact inside the operating switch itself.

Another problem encountered infrequently on the early systems is that the thermal cutout switch has become defective. The switch consists of two fingers with a contact at each end with one finger made out of a bi-metal alloy. When the temperature in the motor housing exceeds a safe value due to overload or fault, the bi-metal finger moves away from the fixed finger and DC power is interrupted. Once the housing has cooled down, the switch closes again. If this happens often, the contacts on the fingers can eventually burn away or the bi-metal finger gets deformed in such a way that the contact no longer closes after cool down. Usually, the bi-metal finger can be manipulated so that it closes again when cold. In extreme cases where the cut-out switch cannot be made to work properly, the switch can be bypassed with a shunt wire. After all, the later units did not have one at all.

## **WARNING**

Note that it is possible under certain fault conditions for the armature to get voltage but for the field to not be energized. This can happen due to bad contacts in the operating switch or when some of the motor wiring is disconnected or making bad contact somewhere along the way. This is an undesirable situation as that will cause the armature to burn out eventually, especially with the later motors without a thermal cutout switch. It can also happen during bench testing of the motor with only some, but not all, of the wiring connected. If bench testing is required, this is best done with a test jig using an original operating switch and a simulated parking switch which is completely wired to all the pertinent motor leads.

## **THE MOTOR**

The motor is the square Lucas shunt style DC motor, used in many automotive applications. It consists of a rotating armature with a commutator section, supported in two porous bronze self-aligning sleeve bearings. The shaft of the armature has a worm gear extension that mates with a round gear in the gear housing. The gear pinion is connected to a bell crank that drives the wiper main drive rod. The motor housing and end plates are sandwiched together with two long bolts that anchor in the gear housing.

Page 5 of 10

Note that the 9.5 – 11 Ohm resistor is a length of resistance wire that is wound on the outside of the field coil for convenience. While the number of turns does affect the magnetic flux of the field to some degree, it is negligible because the number of turns around the field core is very small relative to the field coil number of turns.

This motor style is called a DC shunt model because the armature and the field coil are powered individually, i.e. one shunts the other. These motors have some peculiarities that are worth noting. For the motor to start rotating, both armature and field must have DC power. If only one part gets power, it can burn out eventually because the motor cannot start up. Another property is that the rotational direction of the armature is solely dependent on the polarity relationship of the armature relative to the field. Thus if a motor rotates CW, reversing the DC main power leads will not cause the motor to run CCW. This is because the polarity of both armature and field are now reversed, and so their polarity relationship has stayed the same. For a DC shunt motor to reverse rotation either only the field wires or only the armature wires must be reversed.

Another peculiarity of the DC shunt motor is that reducing the field current actually increases the RPM of the armature. This sounds very counter intuitive, but that is how it works. Available torque has been reduced substantially however.

It is worth noting that the commutator brushes arrangement is very simple. Two spoon type brush holders are used on an isolated pivot plate and a single spring pulls both brushes against the commutator. New brushes are getting hard to find, but it is possible to reuse the spoon style brush holders and fabricate new brushes from larger specimens.

After cleaning, the bronze self aligning bearings must be re-oiled and "1-2-3" light multipurpose oil available at any hardware store can be used.

The gear casing is filled with brown grease that usually has hardened solid over the years. After a good cleaning, repacking with molybdenum fortified wheel bearing grease has been successful so far. White lithium grease tends to dry out very rapidly.

## PIVOT ARM

To Follow

## STEP-BY-STEP OPERATION DETAILS

### SLOW POSITION (See Drawing 75404 #2 of 3)

+12 V DC power comes in on the green motor lead and is connected to one of the armature brushes. The other armature brush is connected to the red motor lead which goes to terminal 3 of the operating switch. Terminals 2, 3 and 6 are interconnected and terminal 2 is connected to ground. Thus the second armature lead is now grounded and so the armature receives 12 VDC.

The blue motor lead is connected to the green motor lead at the armature brush and carries +12 V to switch terminal 4. Terminals 4 and 5 are connected and so the +12 V goes via the white motor wire to the field coil. The other end of the field coil (brown motor lead) goes to switch terminal 6 which is connected to terminal 2 which is ground. Thus the field coil receives 12 VDC and the motor is rotating CW.

Note that the parking switch finger is in contact with its segment, but this is immaterial as the parking switch contact is bypassed by the connection from switch terminal 2 to 3.

### FAST POSITION (See Drawing 75404 3 of 3)

+12 V DC power comes in on the green motor lead and is connected to one of the armature brushes. The other armature brush is connected to the red motor lead which goes to terminal 3 of the operating switch. Terminals 1, 2 and 3 are interconnected and terminal 2 is connected to ground. Thus the second armature lead is now grounded and so the armature receives 12 VDC.

The blue motor lead is connected to the green motor lead at the armature brush and carries +12 V to switch terminal 4. Terminals 4 and 5 are connected and so the +12 V goes via the white motor wire to the field coil. The other end of the field coil goes via the field resistor to the yellow motor wire and to switch terminal 1 which is connected to terminal 2 which is ground. Thus the field coil receives about 5 VDC and the motor is rotating CW but at a higher speed.

Note that the parking switch finger is in contact with its segment, but this is immaterial as the parking switch contact is bypassed by the connection from switch terminal 2 to 3.

**OFF Position (See Drawing 75404 #1 of 3)**

+12 V DC power comes in on the green motor lead and is connected to one of the armature brushes. The other armature brush is connected to the red motor lead which goes to terminal 3 of the operating switch. Terminals 3 and 5 are interconnected and terminal 3 is connected via the parking switch to ground. Thus the second armature lead is now grounded and so the armature receives 12 VDC.

The blue motor lead is connected to the green motor lead at the armature brush and carries +12 V to switch terminal 4. Terminals 4 and 6 are connected and so the +12 V goes via the brown motor wire to the field coil. The other end of the field coil (white motor lead) goes to switch terminal 5 which is connected to terminal 3 which is grounded via the parking switch. Thus the field winding receives 12 VDC and the motor is rotating CCW at a slow speed.

Note that the polarity of the field coil is reversed, compared to the SLOW position. Since the armature polarity has stayed the same as before, the motor rotational direction has now reversed.

Note that the motor continues to run until the finger of the parking switch runs past the copper segment and the parking switch opens up. Both armature and field coil no longer have a ground connection and the motor stops at that point.

75404.DWG		
REVISIONS		
ISSUE	APPR.	DATE
1		7/30/08

PRODUCT:	C/F AutoCad: 75404.DWG		
DATE:	0/30/08	DWG: DAX	APPR:
SCALE:	NTS	DRAWN: DAX	APPR:
DATE:		BY:	APPR:
FARSYS CORPORATION San Carlos, California, U.S.A.			
Lucas 75404 Wiper system			
DATE:		SHEET 1 of 3	DWG NO:
DIST:		75404.DWG	B

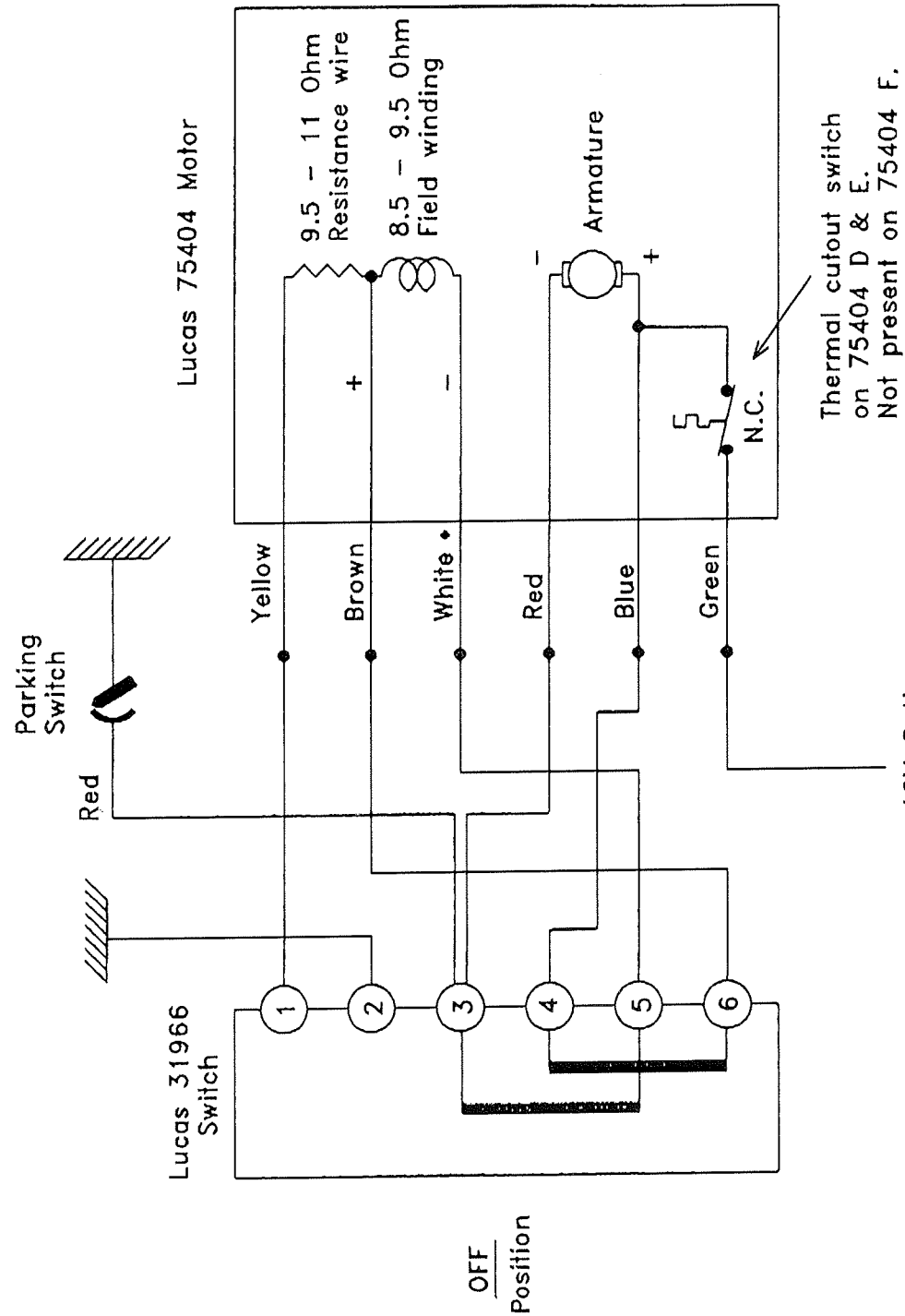

NOTE: The polarity signs reflect neg. ground battery (4.2)  
 For pos. ground battery (3.8) the signs interchange.  
 Alternatively, interpret + to mean battery hot lead and  
 - to mean chassis ground.

OFF  
 Position



75404.DWG		
REVISIONS		
ISSUE	APPR	DATE
1		6/20/08

PRODUCT:	
NEXT ASS'Y:	
C/F AutoCad:	75404.DWG
DATE:	6/20/08
SCALE:	NTS
DRAWN BY:	DAX
CHECKED BY:	OSWALD-DAX
DATE:	6/20/08
APPROVED BY:	
FARSYS CORPORATION San Carlos, California, U.S.A.	
PROJECT:	Lucas 75404 Viper system
DWG. NO.:	
SHEET:	2 of 3
75404.DWG	
B	

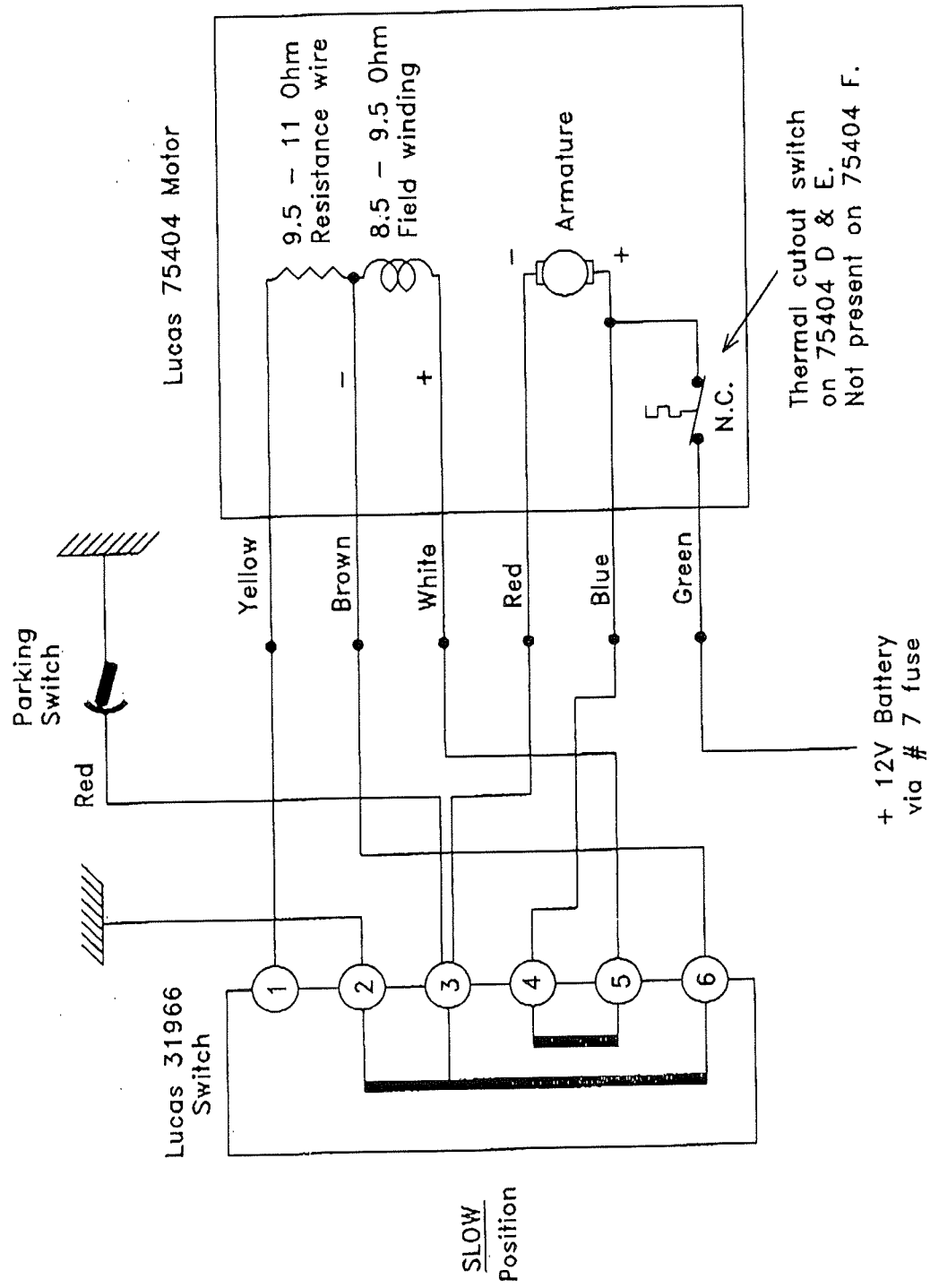

NOTE: The polarity signs reflect neg. ground battery (4.2) For pos. ground battery (3.8) the signs interchange. Alternatively, interpret + to mean battery hot lead and - to mean chassis ground.

75404.DWG

REVISIONS	
ISSUE	DATE
1	5/29/08

PRODUCT:	
NEXT ASSY:	
C/F AutoCad:	75404.DWG
DATE: 6/26/08	ENG: DAX
SCALE: NTS	DRWPR: DAX
DATE:	WTR:
	APPR:
FARSYS CORPORATION San Carlos, California, U.S.A.	
Lucas 75404 Wiper system	
DRAWN BY:	
CHECKED BY:	
SHEET 3 OF 3	DWG SIZE B
	75404.DWG

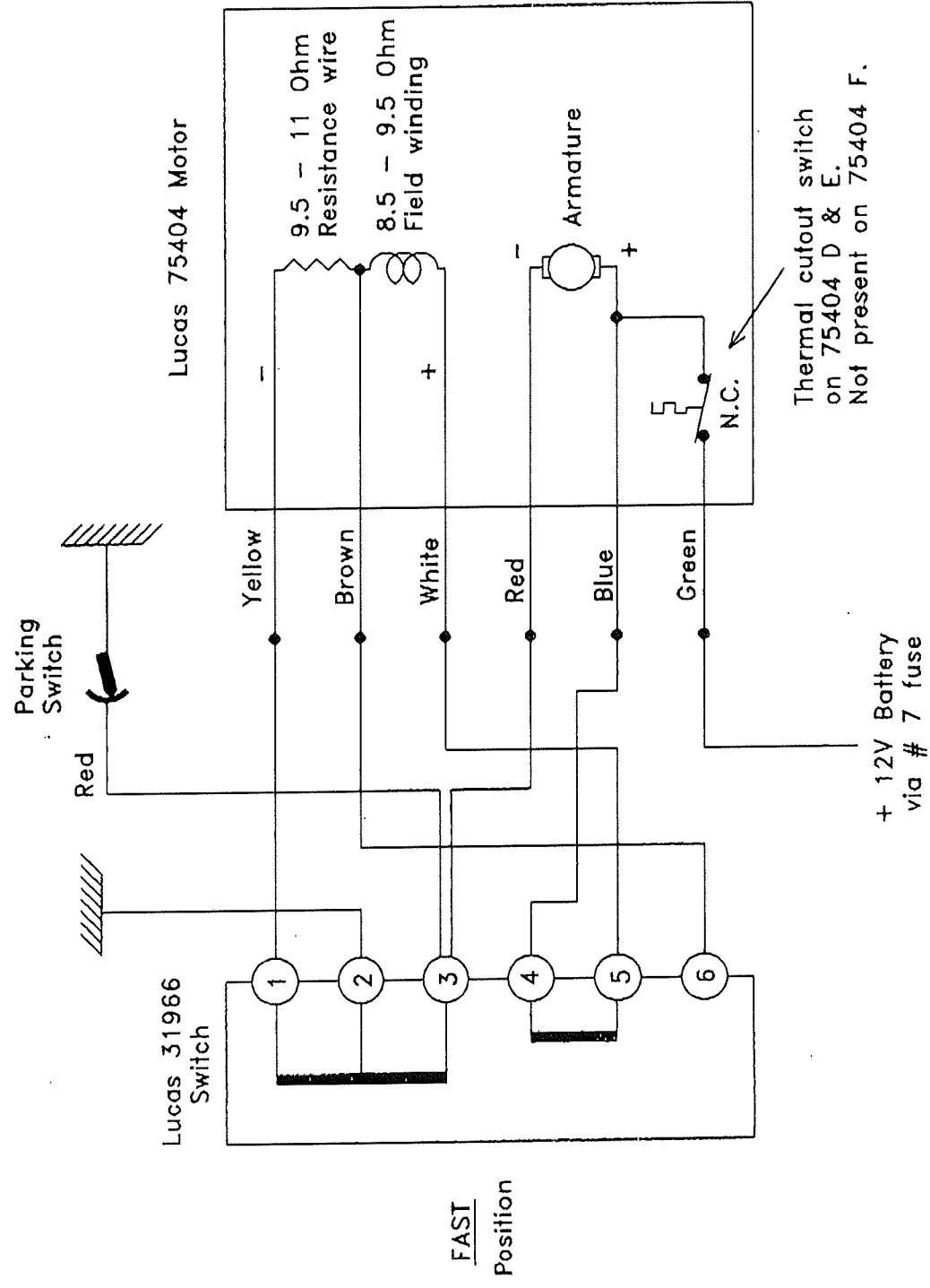

NOTE: The polarity signs reflect neg. ground battery (4.2)  
 For pos. ground battery (3.8) the signs interchange.  
 Alternatively, interpret + to mean battery hot lead and  
 - to mean chassis ground.